

名称 Name	ネジ込揚程式安全弁 Screwed lift type safety valve				図面番号 Drawing No.	参考用		
型式 Type	KANTAB-SU4	呼び径 Nominal dia.		設定圧力 Set press.	MPa	吹止り圧力 Reseatins press.		MPa
流体名 Fl Name		温度 Temperature	°C	吹出圧力 Blowout press.	MPa	作成 Drawn	検図 Check	年月日 Date
規格 Std.		常用圧力 Operating press.	MPa	耐圧試験 Body test	MPa			

備考 Remarks		
承認印 Approval Signature	工事番号 Job No.		

品番 No	部品名 Parts name	数量 Q'ty	材質 Material
01	弁箱 BODY	1	SCS 13A
11	弁座 VALVE SEAT	1	SUS 304
13	弁体 DISC	1	SCS 13A
21	調整リング ADJUST RING	1	SCS 13A
16	弁棒 SPINDLE	1	SUS 304
2B	バネ受 SPRING SEAT	2	SUS 304
2C	バネ SPRING	1	SUS 304
2E	調整ネジ ADJUST SCREW	1	SUS 304
2F	止ナット LOCK NUT	1	SUS 304
03	キャップ CAP	1	SCS 13A
2P	ラチェット RATCHET PIN	1	SUS 316
0P	プラグ PLUG	1	SUS 304
42	ガスケット GASKET	1	PTFE
48	ガスケット GASKET	1	PTFE

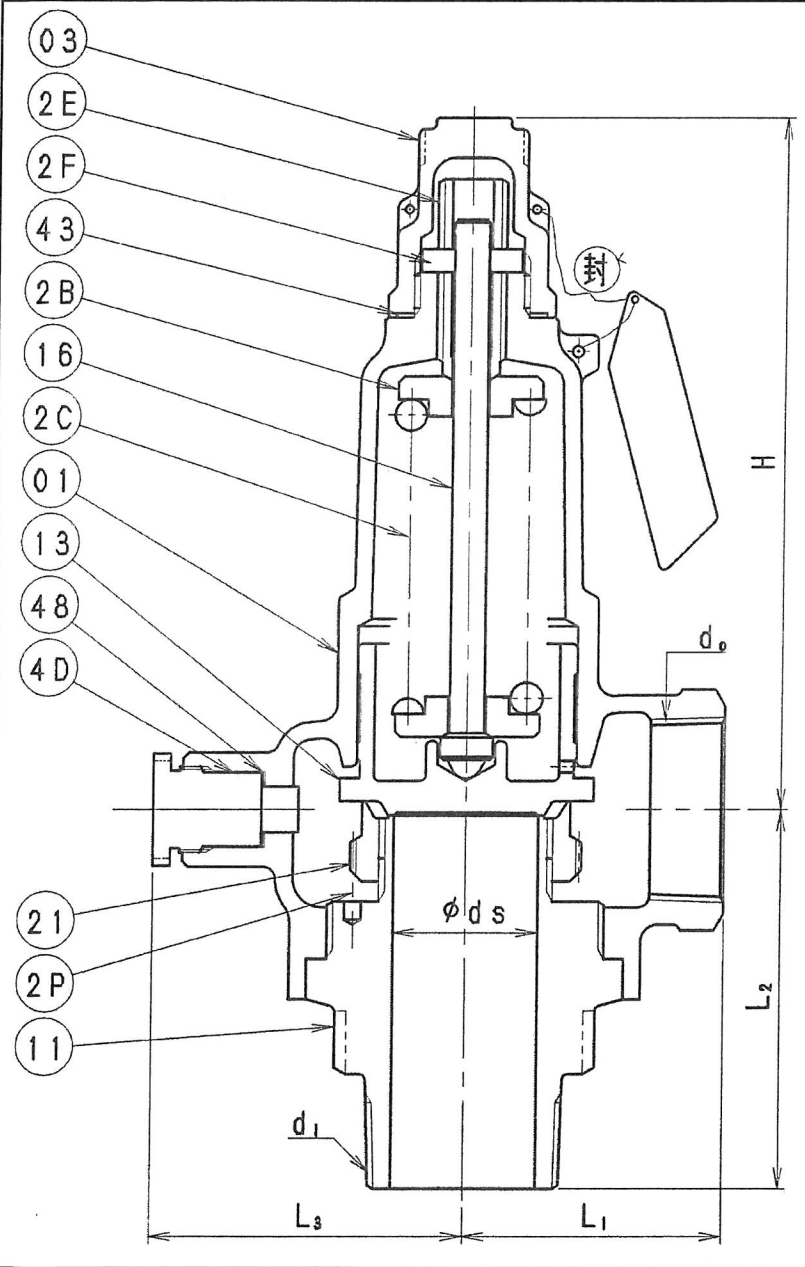

呼び径 Nominal Diameter	弁座径 Seat Dia. ds	リフト Rated Lift L	ノド径 Bore Of Throat	取付寸法 Piping Size		面間寸法 Center To Face			有効面積 (A) Effective Discharge Area $\pi ds L \text{ mm}^2$	
				di	do	L ₁	L ₂	L ₃		H
15 (1/2)	15.0	1.0	13	RC 1/2	RC 1/2	34	53	44	90	47.1
20 (3/4)	20.0	1.3	18	RC 3/4	RC 3/4	41	60	50	105	81.6
25 (1)	25.0	1.6	23	RC 1	RC 1	45	69	54	125	125.6
32 (1-1/4)	32.0	2.1	30	RC 1-1/4	RC 1-1/4	58	80	69	165	211.0
40 (1-1/2)	38.0	2.6	36	RC 1-1/2	RC 1-1/2	66	88	74	180	310.2
50 (2)	50.0	3.3	48	RC 2	RC 2	80	106	90	205	518.1

UNIT (mm)